



**For further information on the
JARRETT Cranes & Winches range of
products**

Contact Us

Telephone: +61 8 9244 4566

Facsimile: +61 8 9244 4577

Address: Unit 2/81 Guthrie Street, Osborne Park WA 6017

Email: info@accessunlimited.com.au

Web: www.accessunlimited.com.au

300 Series Brake Winch

5:1 ratio model (300kg)

MODEL:	NO COVER
No Cable	F10341
Cable	F10340
GEAR RATIO	5:1
APPLICATION	Lifting
Rated Capacity	300kg (2940N)
Mass (no cable)	4.75kg
Type of Brake	Self Action
Drum Diameter	50mm
Flange Diameter	127mm
Drum Width	45mm
Maximum Cable Capacity	15m x 5mm
Maximum Effort on handle at Rated Load	26kg
Cable Breaking Strain	1905kg
Cable (as supplied) - Galv	7.5 x 5mm

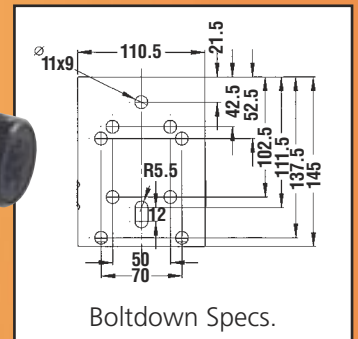
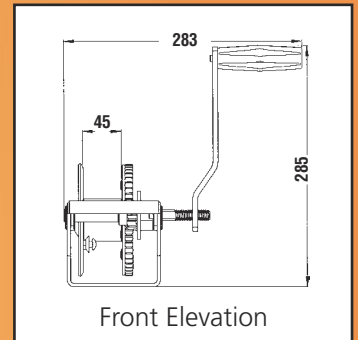
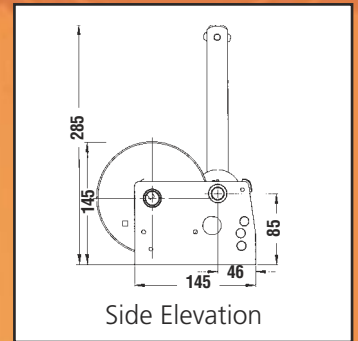

FEATURES INCLUDE:
 Heavy duty 4mm winch body, Steel bushes,
 Machined gears, Self actuating brake mechanism
 300kg capacity, Electroplated zinc cobalt,
 Powder coated finish